

KAE

Gas Alarm Operation Manual

Henan Hanwei Electronics Co.,Ltd

ISO9001-2008

Precautions:

To avoid personal safety injury, Instrument damage and potential dangerous accident; do not use gas detector before reading this manual.

1 Description

KAE-HD gas alarm is a kind of wall-mounted household gas alarm designed to detect the concentration of combustible and toxic gases or vapors using high quality air-sensitive component and manufactured with advanced technology. It provides visual and audible signals when the gas concentration reaches the presetting range, and reminds you to take prompt favorable action.

2 Specifications

* The Alarm point can be specified.

Model	KAE-HD
Detecting gas	Combustible gas, CO
Sensor type	Semiconductor sensor, electrochemical sensor
Gas Sampling	Diffuse naturally
Detecting range	Combustible gas: 0~20%LEL, CO:0~500ppm
Preset alarm point	Combustible gas: 7%LEL, CO: 100ppm
Warming time	3 min
Response time	≤30s
Resume time	≤30s
Working voltage	AC220V 50Hz
Power Consumption	≤1.5W
Alarm method	Visual and audible
Alarm sound	≥85dB
Working Environment	Temperature: 0℃~55℃ Humidity: <95% Atmosphere pressure: 86 kPa~106 kPa
Sensor life	>3 years
Weight	240g
Dimension	lxbxh,mm:170x100x45

3 Functions and Indications

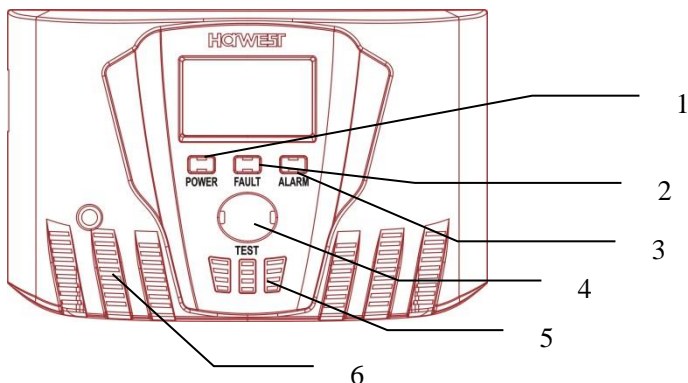

1	Green light	Power indication
2	Yellow light	Fault indication
3	Red light	Alarm indication
4	Button	Test
5	Sound window	Sound indication window
6	Air vent	Detection

4. Installation

4.1 Fix the appliance on the wall or ceiling at a horizontal distance as 2~4m from the cooker or gas source;

4.2 The vertical location of the appliance should be decided according to the type of gas sources.

- ◆ LPG: Within 0.3 meters above the ground. (LPG is heavier than air.)
- ◆ Natural Gas or coal gas: Within 0.3 meters below the roof. (Natural Gas or coal gas are lighter than air.)
- ◆ Such location should be avoided:
 - Near the windows or passage with strong wind;
 - Water fog and drop or such moist place;

- Easy polluted or high tem environment near oven;
- Covered by other things.

4.3 Choosing a proper installation way per conditions above.

Installation 1: Choose a suitable wall or place per the above 4.1, 4.2 requests. Fix the hanging plate onto the wall with M5 or M3 screw through the screw hole (as the following drawing, two optional types $\phi 5$ and $\phi 3$), then connect the detector with the hanging plate.

Installation 2: Choose a suitable wall or place per the above 4.1, 4.2 requests. Fix a nail (size $\phi 2$) into the wall. Hang the detector on the nail directly with the hanging hole as the drawing below:

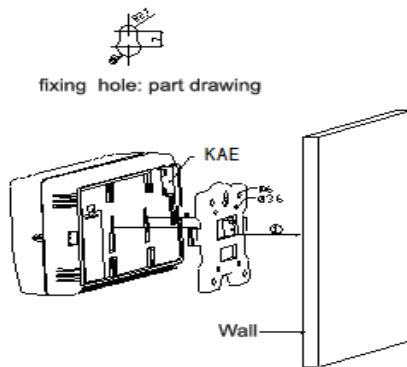

4.4 Regarding the detector with valve and relay, please connect it in accordance with the following picture:

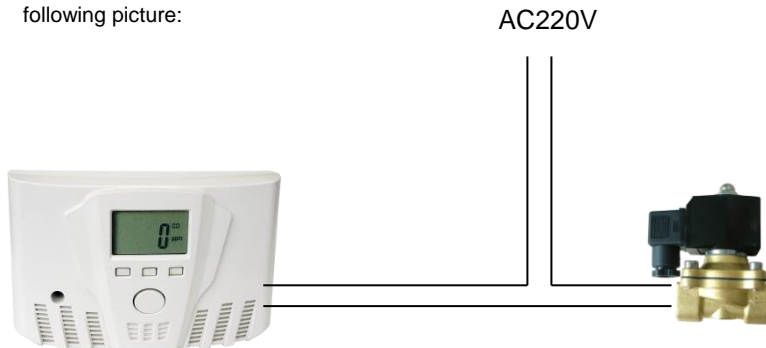

Note: Shut-off devices must comply with local regulations.

5. Functions and instructions

5.1 Power on: Plug in, then the green Power light, there is 8888 on the LCD, the warming time is 3 minutes.

5.2. Detecting status, it displays the concentration of carbon monoxide or combustible gas on the LCD screen, when the two gases are existing, it displays the concentration by turns.

5.3. Alarming: If the gas in the environment rises above the presetting alarming level, the detector enters alarming status. The red ALARM light will flicker quickly and the buzzer will give sound alarming.

5.4. Fault status: If the yellow fault alarm light is on, it shows there is something wrong with the detector and the detector can't detect gas. Please contact the distributor.

5.5 Self-check: Under no detecting status, the three lights will flicker simultaneously and the buzzer will tweet coupled with the relay closed by pressing TEST button.

6. Operation and self-check

6.1.Plug in, after 3 minutes warm up, the detector enters into detecting status, If the gas in the environment rises above the presetting alarming level, the detector enters alarming status. Then please cut off gas supply promptly and open windows. Switching on or off any electric appliance is highly prohibited, including mobile phone and such communication tools. Once the gas concentration drops under the presetting alarming level, the appliance will resume to detecting status automatically. Ask professional person to eliminate the gas leaking malfunction quickly.

If the yellow fault alarm light is on, it shows there is something wrong with the detector and the detector can't detect gas. Please contact distributor.

6.2 please make the self-check every 30 days.

7 Troubleshooting Guide

Problems...	Maybe caused by...	You should...
Green POWER light is off	Power lacking	Plug in the power again to assure the unit receive power

	Light broken	Contact the distributor or factory for repairing
No alarm after pressing test button	Circuit fault	Contact the distributor or factory for repairing
Can't detect the gas	The preheat is not finished	Wait until the preheat finish
	Circuit fault	Contact the distributor or factory repairing
Keep alarming after warm up	Too much smoke, alcohol or perfume or other volatility gas in the air.	Test again in the clean air
	Stored too long	Warm up for more than 2 hours
	Circuit fault	Contact the distributor or factory maintain

8 Notices

8.1 It's possible that the detectors give alarming in the conditions of being kept in long time smoking, drinking, or using perfume, gasoline, paint and other volatile organic compound;

8.2 Please do not use some non-calibrated gas to test the detectors. If the gas concentration is too high, it will damage the detectors. Also it is harmful for human's health;

8.3 Please contact the dealer/ distributor/manufacturer for periodical maintenance according to the specified gas sample and concentration in clause.

8.4 Please do not use or store the detectors in the corrosive gases (such as Cl₂);

8.5 Clean the dust or dirt on the alarm frequently to keep air vent freely and the lights clear

8.6 The detector needs to be keeping power on for more than 24 hours after a long time delivery of storage.

8.7 The life of sensor is more than 3 years in normal detection.

9 Gas Safety Knowledge

9.1 The sorts of flammable gas and dangerous of gas leakage:

Normal domestic gas: LPG: propane and butane;

Coal Gas: hydrogen and carbon monoxide;

Natural Gas: methane;

Tel: 86-37167169070/80

- 5 -

Email: sales@hwsensor.com

All of the normal domestic gases is combustible gas, whose LEL (lowest explode limited) is below 10% of mixture with air.

When the concentration of the leaking gas in air, it will narcotize people's centre nerve, even cause suffocation. The coal gas includes much CO, and could also engender CO when being incomplete burning.

Gas	Basis	Exploding Range	Toxicity
LPG	C ₄ H ₁₀ 、C ₃ H ₈	1.8%~9.5%	suffocation
Natural Gas	CH ₄	5%~15%	suffocation
Coal Gas	H ₂ 、CO	4%~75%	toxicosis

9.1 When the gas burning, it need abundant air, such as 1m³ LPG needs about 30m³ air.
So the placed with hearth such as kitchen has to be keep ventilate.

9.2 Meaning of typical units

%LEL: LEL is Lowest Explode Level. That is the lowest concentration of the gas in the air, which will cause exploding when meeting fire.

%vol: Volume ratio Seldom use "vol";

Ppm: Millionth of volume ratio.

9.3 It is not harmful when little flammable gas leak occurred because it will not arose fire or explosion. Whereas, if the leakage is lack of control and it accumulates gradually, when the increasing gas come to certain extent, it is easy to explode provided meeting naked flame. That is LEL. LEL is not the same for different combustible gas, for instance, the LEL of methane is 5%. It means, if the concentration of methane is below 5%, no explosion accident will occur even with naked flame or spark. But if the methane concentration reaches or exceeds 5%, it is easy to explode when meeting naked flame. Therefore, a reliable and favorable gas alarming system is quite significant to avoid the malignant accident in domestic and industrial fields. Normally, the alarming point is a key index in judging the performance of alarming system and generally to be set at 1%-25% below gas LEL.

9.4 Reasons of gas leakage:

- Wrong ignition.
- The fire is put out with winds during the cooking.

- Fire is out during the cooking because of the change of the gas pressure.
- The gas valve is not shut off well.
- Wrong operation to the cooking tools.
- The gas pipe is destroyed.
- Other reasons.

9.5 Solutions of gas leakage:

- Put out the fire.
- Shut off the gas valve.
- Open the windows and doors.
- Check the leakage source.
- Don't try to turn off any electric equipment when alarming continuously. Call the gas company with the outdoor phone.

Please knock at the door instead of pressing the doorbell when find gas leakage in your neighbors' home.

HANWEI ELECTRONICS CO., LTD

No.169, Xue Song Road National Hi-Tech Zone,

Zhengzhou 450001, China

Phone: +86 371 67169070/67169080

Fax: +86 371 67169090

E-mail: sales@hwsensor.com

Website: www.hwsensor.com