

Venus

Carbon Monoxide Detector Operation Manual

Henan Hanwei Electronics Co., Ltd

ISO9001-2000

1. Brief introduction

Venus carbon monoxide gas detector, adopting high quality electrochemical gas sensor and advanced technology, has the advantages of good stability and long life span. The installation method can be tap-top, ceiling hung and wall mounted. Easy to install and operate. When the CO concentration in the air reaches the presetting alarming level, the detector will give audio and video alarming promptly, which informs the user to adopt measurement to avoid the fire, explosion etc. dangerous accidents happening.

2. Specifications

| | |
|---------------------|--|
| Model | Venus |
| Working voltage | DC9V |
| Working Current | < 170uA |
| Alarming current | < 20mA |
| Accuracy | Follow EN50291 |
| Detecting gas | Carbon Monoxide |
| Working Environment | Temperature: -10℃~50℃ Humidity: <95%RH |
| Gas Sampling | Natural diffusion |
| Alarm method | Visual and audible |
| Alarm sound | ≥90dB(1m) |
| Sensor type | Electrochemical carbon monoxide sensor |
| Sensor life | >5 years |
| Weight | About 240g |
| Dimension | dxh ,mm:124x38 |

3. Function and indication

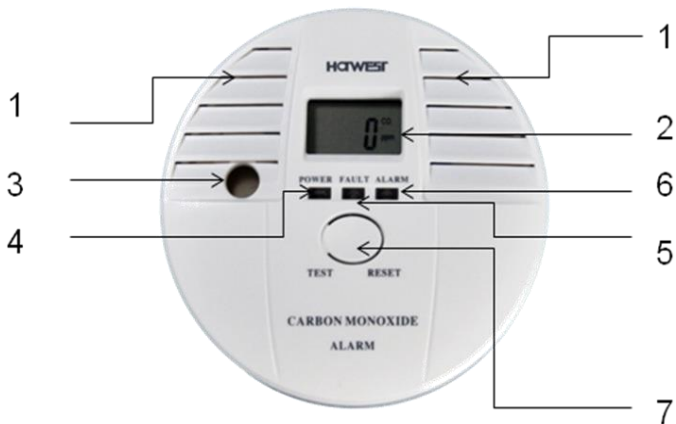

| No. | Function |
|-----|-------------------|
| 1 | Detection window |
| 2 | LCM screen |
| 3 | Buzzer hole |
| 4 | Power LED: Green |
| 5 | Fault LED: Yellow |
| 6 | Alarm LED: Red |
| 7 | Test/Reset button |

4. Installation

4.1 Installation position

The detector and the fuel using device should be installed inside the same room.

- If the detector is wall mounted, its height should be higher than any door or window, and at least 150mm to the ceiling. If the detector is ceiling hung, the distance between it and any wall should be more than 300mm.
- The detector should be horizontally 1-3 meters to the gas source.
- If there is obstacle inside the room, then the detector and the potential gas source should be in the same side of the obstacle.
- If in the room with slant ceiling, the detector should be installed in the higher side of the room.
- The detector should be installed nearby to the place where user always breathes.

4.2 Avoid installed to the following places:

- Outside of the building
- Inside or below the Fresh cabinet
- Right upper of the water pool or cooking utensils
- Near the window or easily influenced by the air flow, like exhaust fans or holes.
- The place where the air flow through the detector is easily blocked by the curtain or furnace.
- The place where the gas sensor is easily blocked by the dust.
- The place where the temperature is out of the range of -10°C to 50°C.
- The place where the detector is easily touched, broken or moved.
- The place where it's moist.

4.3 Installation rooms

Ideally, install one detector in each room where there is fuel using device. If there are more fuel using devices while the detector quantity is limited, please consider the followings to decide the installation position:

Please install one detector inside the bedroom which has fuel using device.

Please install one detector inside the room where there is a non-chimney or normal chimney fuel using device.

Please install one detector inside the room where there is electric machine.

Inside the bedroom and sitting room, the detector should be far away from the cooker and be near to the sleeping place.

The detector should be installed outside the room if the fuel using device is installed inside the room where the device is not used frequently (such as the boiler room). So that the alarm sound can be heard easily.

4.4 Installation configuration

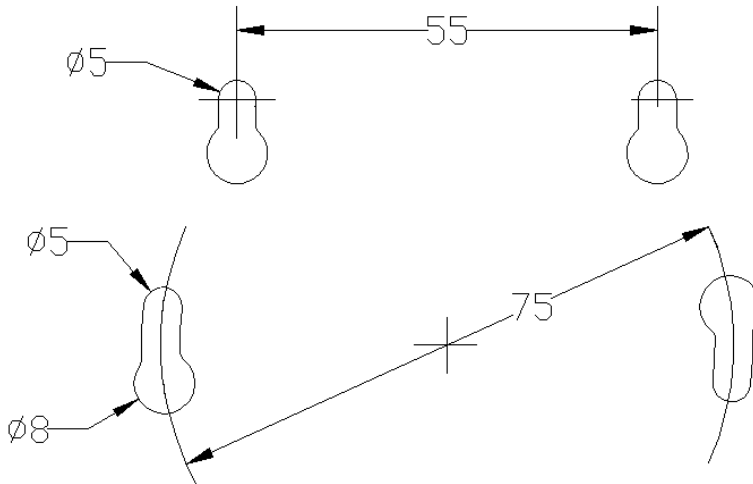

4.5 Installation method

4.5.1 Tap top:

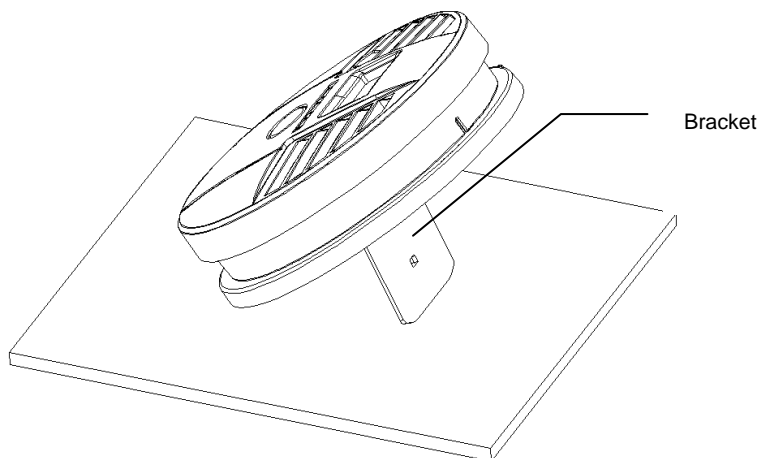

4.4.2 Wall mounted:

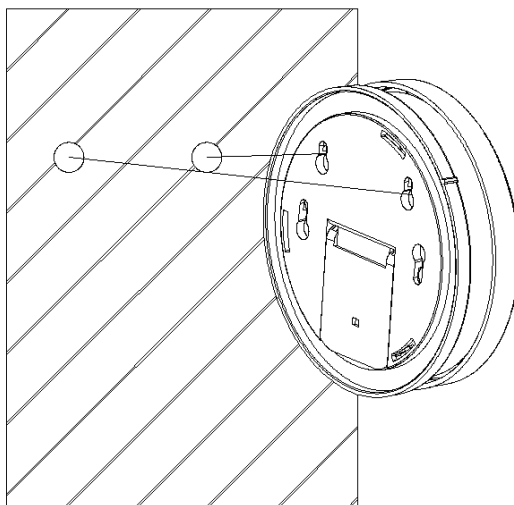

Dimensions of the fixing holes

Please choose the suitable wall firstly. Fix M5 screw on the wall with distance as 70mm. The screws should be 3.5mm higher than the wall. Then hang the detector on the wall as

the above drawing.

4.4.3 Ceiling hung

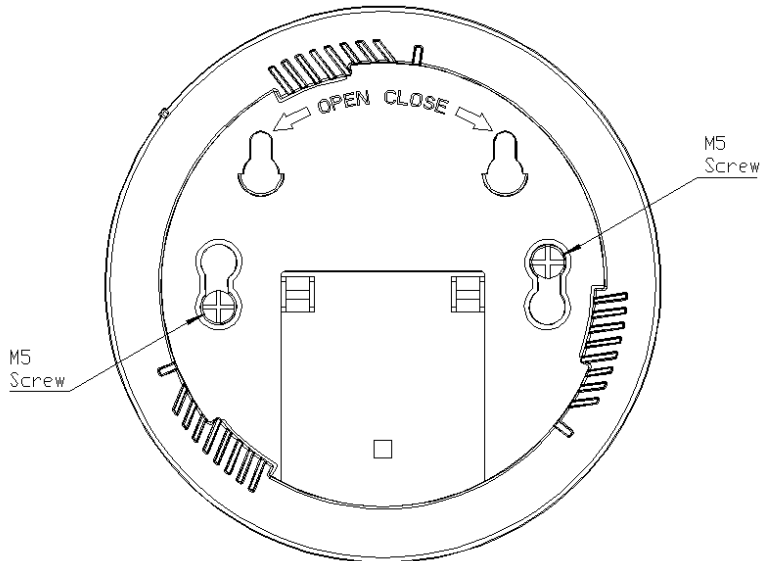

Choose the suitable ceiling. Fix the panel on the ceiling with M5 screw, then rotate the upper and down covers in different direction. The upper cover should be rotated clockwise.

4.4.4 Battery installation

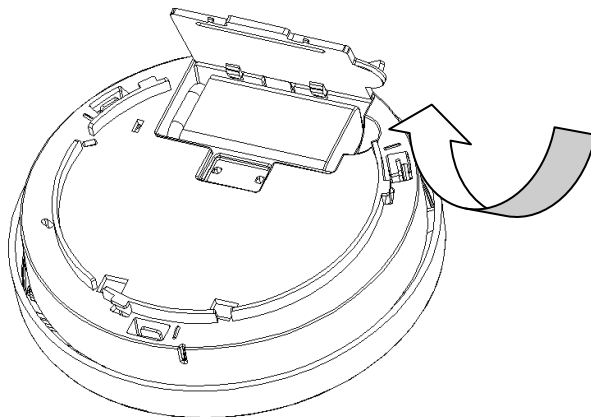

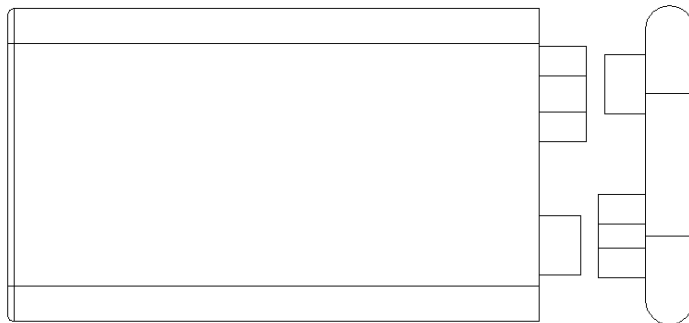

First, please turn off the battery cover according to the orient on the above drawing. And then, install the batteries inside according to the indication.

Note: Please replace the used batteries with 9V same new batteries. Different type or low quality battery will reduce life of the detector.

5. Operation instruction

5.1.1. Power On:

When power on, the detector shall enters a 1 minutes long time delay status, the Green power LED will blinks every 15 seconds, and the screen displays a "0" that stops flashing when the time delay status ends. After the time delay, the detector enters monitoring status and the screen displays a "0".

5.1.2. Self-Test

Press the test /reset button, the power LED, fault LED and alarm LED will flash four times, the buzzer will beep four times simultaneously.

5.1.3 Monitoring and Alarming

The Green Power LED flashes once every other 15 seconds, and the buzzer beeps once to confirm the detector is under normal detection status. When alarm is triggered, the red ALARM LED flashes 4 times every 4 seconds with the buzzer beeping four times at the same time. The flashing and beeping will repeat until CO concentration is below the alarm level.

5.1.4 Fault or Low battery

The fault LED flashes once every other 15 seconds, and the buzzer beeps once when the sensor fails. When the battery need to be changed, the fault LED flashes , and the buzzer

beeps once every 30 seconds, and the screen displays a “L”.

5.1.5. THIS CO ALARM MEETS THE FOLLOWING ALARM TIME / CONCENTRATIONS REQUIREMENTS:

At 30 PPM, the unit makes no alarm in less than 120 minutes

At 50 PPM, the unit makes alarm within 60-90 minutes

At 100 PPM, the unit makes alarm within 10-40 minutes

At 300 PPM, the unit makes alarm within 3 minutes

6. Maintenance of the detector

The detector was calibrated at the factory. During using it, please always clean the housing of the detector and keep the gas windows not being covered by dust. Please use soft cloth or brush to clean the housing. Cleanser, bleaching powder and polish are forbidden to be used for cleaning.

Termination of the detector life:

In detecting status, the detector makes self test once every minute.

Under normally working condition, the detector can work 5 years. When the detector life is terminated, please dispose it according to the local regulation.

Warning: This detector is designed for domestic use. Please avoid it from rain, moisture, dropping, beating, opening and modifying. Otherwise, the operation will cause problem to the detector.

7. Troubleshooting

| Phenomenon... | Possible reason | Solution |
|-------------------------------------|---|--|
| Green power LED off | Battery fault connected or power supply problem | Change battery installation position or make the connection in a correct way |
| | LED broken | Contact the distributor |
| No alarm after pressing test button | Circuit fault | Contact the distributor |

| | | |
|-----------------------------|--|--|
| Can not detect CO | Warm-up doesn't finish | Wait until warm-up finishes |
| | Circuit fault | Contact the distributor |
| Keep alarming after warm-up | Too much smoke, alcohol or perfume or other volatile gas in the air. | Move it into clean air and test it again |
| | Stored for long time | Electrify it for more than 2 hours |
| | Circuit fault | Contact the distributor |

8. Notice

8.1 It's possible that the detector makes alarm in the environment with much smoke, alcohol, perfume, gasoline, paint and other volatile gases.

8.2 Please do not use unknown-concentration gas to test the detectors. If the gas concentration is too high, it will damage the detector. Also it is harmful for the health of the user.

8.3 Please contact the dealer/distributor/manufacture for annual periodical maintenance with the standard gas.

8.4 Please do not use or store the detectors in the corrosive gases (such as Cl₂) environment.

8.5 Clean the dust or dirt on the detector frequently to keep air vent unblocked and the indicators clear.

8.6 In order to assure the best sensitivity, please electrify it for at least 24 hours when you use it the first time after long time shipment or storage.

8.7 Lifetime of the detector is 5 years in normal detection. In order to get accurate detecting result of CO and protect your life and belongings safety, we strongly suggest you change a new detector when its lifetime over.

9. Packing list

| | |
|--------------------|------|
| Venus gas detector | 1pc |
| M5 bolt | 2pcs |
| Operation manual | 1pc |

HENAN HANWEI ELECTRONICS CO., LTD

No.169, Xuesong Road National Hi-Tech Zone,

Zhengzhou 450001, Henan, China

Phone: +86 371 67169070/67169080

Fax: +86 371 67169090

E-mail: sales@hwsensor.com

Website: www.hwsensor.com